



Selection: Open Screw Compressors OS

Input Values

Compressor model	OSN7461-K	Operating mode	Economizer
Refrigerant	R404A	Speed	2900 /min
Reference temperature	Dew point temp.	Useful superheat	100%
Liq. subc. (in condenser)	0 K	Additional cooling	Automatic
Auto. subcooling	Auto	Max. discharge gas temp.	80,0 °C
Suct. gas superheat	10,00 K		

Result

Q [W]	Cooling capacity	Qac [kW]	Additional cooling
P [kW]	Power input	tcu [°C]	Liquid temp.
COP [-]	COP/EER	pm [bar(a)]	ECO pressure
mLP [kg/h]	Mass flow LP	Qsc [kW]	sub cooler capacity (ECO)
mHP [kg/h]	Mass flow HP		

tc	to	-15°C	-20°C	-25°C	-30°C	-35°C	-40°C	-45°C	-50°C
30°C	Q [W]	150471	126285	105034	86414	70146	55973	43667	33020
	P [kW]	45,5	43,7	42,0	40,4	38,9	37,3	35,7	33,9
	COP [-]	3,31	2,89	2,50	2,14	1,80	1,50	1,22	0,97
	mLP [kg/h]	3768	3121	2558	2070	1651	1293	988	731
	mHP [kg/h]	4341	3717	3155	2651	2198	1793	1432	1109
	Qac [kW]	--	--	--	--	--	--	3,09	7,87
	tcu [°C]	15,99	12,60	8,98	5,09	0,94	-3,49	-8,20	-13,19
	pm [bar(a)]	7,28	6,56	5,85	5,16	4,48	3,84	3,24	2,68
	Qsc [kW]	21,5	22,1	21,8	20,8	19,26	17,27	14,96	12,43
40°C	Q [W]	140266	117730	97948	80610	65444	52209	40696	--
	P [kW]	55,1	53,5	51,9	50,2	48,5	46,7	44,8	--
	COP [-]	2,55	2,20	1,89	1,60	1,35	1,12	0,91	--
	mLP [kg/h]	3743	3091	2525	2036	1616	1259	956	--
	mHP [kg/h]	4595	3940	3349	2818	2342	1914	1531	--
	Qac [kW]	--	--	--	--	2,96	8,24	13,01	--
	tcu [°C]	22,0	18,46	14,66	10,53	6,07	1,27	-3,89	--
	pm [bar(a)]	8,68	7,84	6,99	6,15	5,32	4,53	3,79	--
	Qsc [kW]	28,9	28,4	27,1	25,2	22,9	20,2	17,20	--
50°C	Q [W]	125784	105547	87741	72073	58290	46177	35553	--
	P [kW]	67,5	66,0	64,4	62,8	60,9	58,9	56,6	--
	COP [-]	1,86	1,60	1,36	1,15	0,96	0,78	0,63	--
	mLP [kg/h]	3648	2997	2431	1944	1526	1171	870	--
	mHP [kg/h]	4808	4126	3509	2952	2449	1994	1582	--
	Qac [kW]	--	--	9,12	14,58	19,58	24,0	27,8	--
	tcu [°C]	29,0	25,3	21,3	16,77	11,85	6,48	0,62	--
	pm [bar(a)]	10,60	9,56	8,51	7,45	6,41	5,40	4,44	--
	Qsc [kW]	34,9	33,4	31,3	28,6	25,5	22,0	18,37	--

-- No calculation possible (see message in single point selection)

*According to EN12900 (10K suction gas superheat, liquid subcooling in Economiser with 5K temperature difference)

Application Limits ECO OSN7461

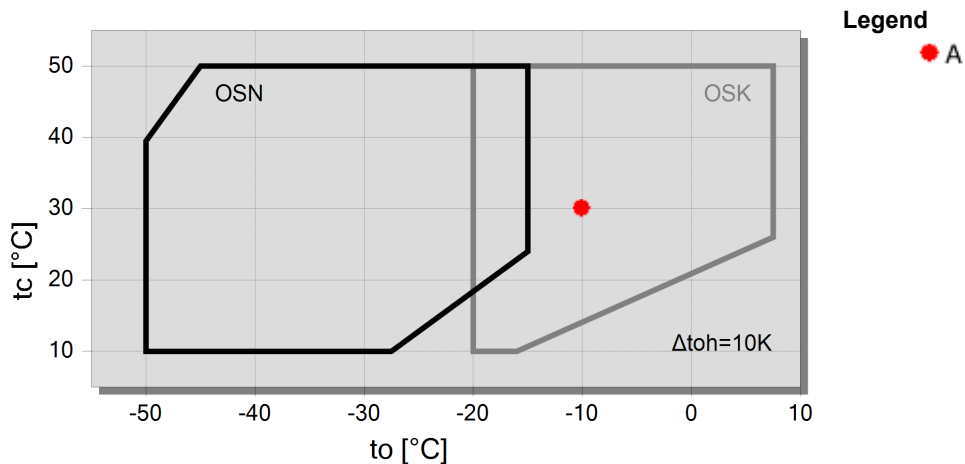



Technical Data: OSN7461-K

Dimensions and Connections

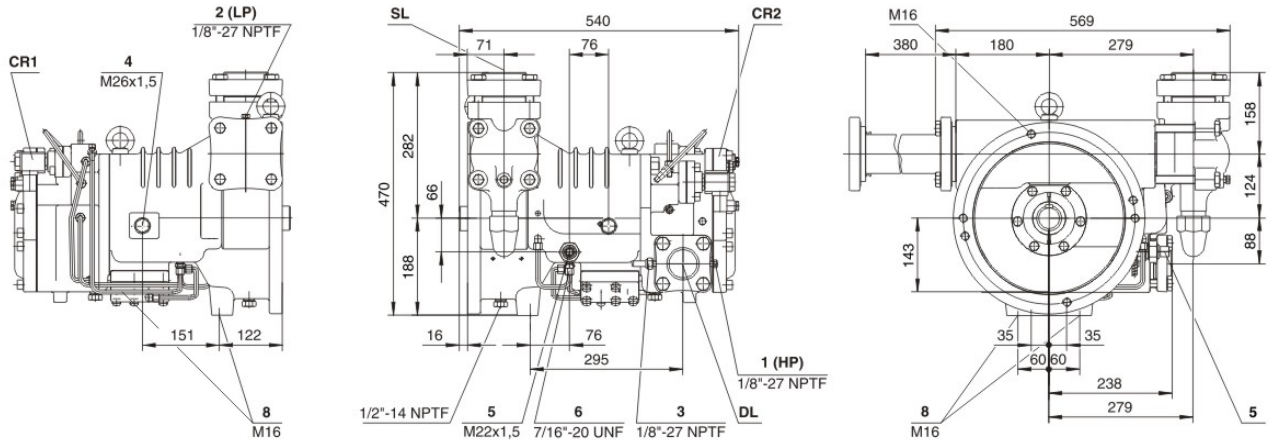

Technical Data

Technical Data

Displacement (2900 RPM 50 Hz)	220 m ³ /h
Displacement (3500 RPM 60 Hz)	266 m ³ /h
Allowed speed range	1450 .. 4000 min-1
Sens of rotation (compressor)	links / counter-clockwise
Weight	176 kg
Max. pressure (LP/HP)	19 / 28 bar
Connection suction line	76 mm - 3 1/8"
Connection suction line (NH3)	DN 80
Connection discharge line	54 mm - 2 1/8"
Connection discharge line (NH3)	DN 50
Oil type R22	B150SH, B100 (Option)
Oil type R134a/R404A/R507A/R407A/R407F	BSE170 (Option)

Extent of delivery (Standard)

Suction shut-off valve	Standard
Pressure relief valve	Standard
Check valve	Standard
Oil injection kit	Standard
Built in oil filter	Standard
discharge gas temperature monitoring	SE-B2
Discharge gas temperature sensor	Standard
Start unloading	Standard
Capacity control	100-75-50% (Standard)
Sight glass	Standard
Protective charge	Standard

Available Options

Oil flow control	Option
Discharge shut-off valve	Option
ECO connection with shut-off valve	Option
Adapter/shut-off valve for ECO	22 mm - 7/8" (Option)
Coupling housing	Option



Open Screw Compressors OS

OSK = Application for air-conditioning and medium temperature cooling.

OSN = Application for low temperature cooling.

OSH = Application for air-conditioning and heat pumps.

Notes regarding application limits (see "T.Data - Limits")

* Ranges are valid for standart operation and at full-load conditions.

* With high pressure conditions, part-laod operation is partly limited (see application limits in applications manual SH-500 / SH-510).

* With Economizer operation the maximum admissible evaporation temperature is shifted by 10 K downward (otherwise there is a danger of excessive compression and overlaod of the motor because of a higher mass flow). At pull-down conditions from higher evaporation temperatures, the ECO injection must remain closed until the evaporation temperature is below the maximum admissible value and a stable operation is achieved (e.g. control of the ECO solenoid valve by means of a low pressure cut-out). The use of the ECO-System with higher evaporation temperatures requires individual consultation with Bitzer.

OS53..OS74

* Capacity control with ECO operation at the same time is limited to one single regulating step (CR 75 %). At CR 50 % the ECO injection should be closed.

* Combined operation (ECO + CR 50 %) is possible under certain conditions, control and system design, however, require individual consultation with Bitzer.

Motor Selection

The required driving motor is selected for starting conditions at direct start as well as at star-delta-start with start unloading (50 % capcaity regulation). The starting conditions refer to the following defined operation points resp. to the maximum application limit of the compressor. Should the evaporation- or the condensing temperature of the plant be higher at the start, an individual motor selection is necessary.

	Evaporation temperature for motor selection			
	HH	H	M	L
R134a	+20 °C	+12,5 °C	-5 °C	
R404A / R507A		+7,5 °C	-5 °C	-15 °C
R22		+12,5 °C	-5 °C	-10 °C
R407C		+12,5 °C	-5 °C	
NH□	+25 °C	+12,5 °C	-5 °C	-10 °C

The stated motor data refer to IEC motors at which the pull-up torque should not fall below 90 % of the max. torque. In addition the following starting torque (referring to direct start) must be reached:

* open screw compressors 120 %

Should the motor not fulfil these criteria, an individual selection is also necessary.

Lubricants and additional cooling for NH3 applications

	Type	Viscosity	Discharge gas temp. (°C)	Oil injection temp. (°C)
Reniso KM32	MO	32	ca. 60 .. max. 100	max. 50
Reniso KS46	MO	46	ca. 60 .. max. 80 (100 [1])	max. 60
Reniso KC68	MO	68		
Reflo 68A	MO (HT)	58		
SHC226E	PAO	68		

[1] 100°C only after consultation with BITZER

Further information on the selection of lubricants can be found in the Application Manuals SH-500 and SH-510.

Legend of connection positions according to "Dimensions":

- 1 High pressure connection (HP)
- 1a Additional high pressure connection
- 1b Connection for high pressure transmitter (HP)
- 2 Low pressure connection (LP)
- 2a Additional low pressure transmitter (LP)
- 2b Connection for low pressure transmitter (LP)
- 3 Discharge gas temperature sensor connection (HP)
- 4 Connection for economiser (ECO)
- HS.85: ECO valve with connection pipe (option)



HS.95, OS.85, OS.95: ECO valve (option)
5 Oil injection connection
6 Oil pressure connection for HS.85 and OS.85:
Oil drain (compressor housing)
7 Oil drain (motor housing)
7a Oil drain (suction gas filter)
7b Oil drain out of shaft seal (maintenance connection)
7c Oil drain tube (shaft seal)
8 Threaded bore for foot fastening
9 Threaded bore for pipe support (ECO and LI line)
10 Maintenance connection (oil filter)
11 Oil drain (oil filter)
12 Monitoring of oil stop valve
OS.85: Monitoring rotation direction and oil stop valve
13 Oil filter monitoring
14 Oil flow switch
15 Earth screw for housing
16 Pressure relief (oil filter chamber)
17 Maintenance connection for shaft seal
18 Liquid injection (LI)
19 Compressor module
20 Slider position indicator
21 Oil level switch
22 Connection for oil pressure transmitter
23 Connection for oil and gas return
(for systems with flooded evaporator adaptor optional)
24 Acces to oil circulation restrictor
SL Suction gas line
DL Discharge gas line
Dimensions can show tolerances according to EN ISO 13920-B.